

REPLACEMENT

1. REPLACE VALVE GUIDE BUSHINGS

(a) w/ Snap Ring:

Insert an old valve wrapped with tape into the valve guide bushing, and break off the valve guide bushing by hitting it with a hammer. Remove the snap ring.

HINT:

Wrap the tape approx. 8 mm (0.31 in.) from the valve stem end.

NOTICE:

Be careful not to damage the valve lifter hole.

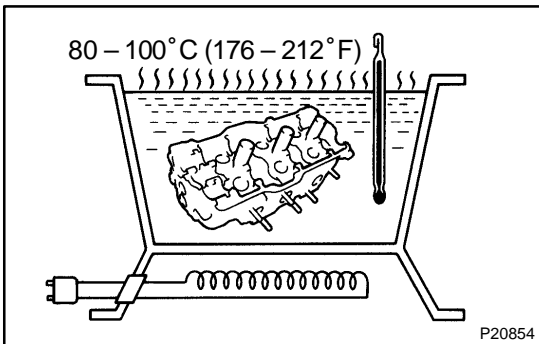

(b) Gradually heat the cylinder head to 80 - 100°C (176 - 212°F).

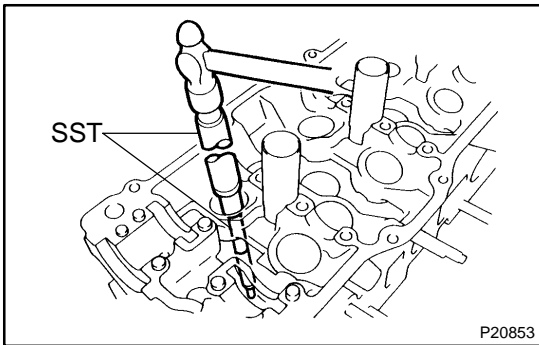

(c) Using SST and a hammer, tap out the guide bushing.
SST 09201-10000 (09201-01060),
09950-70010 (09951-07150)

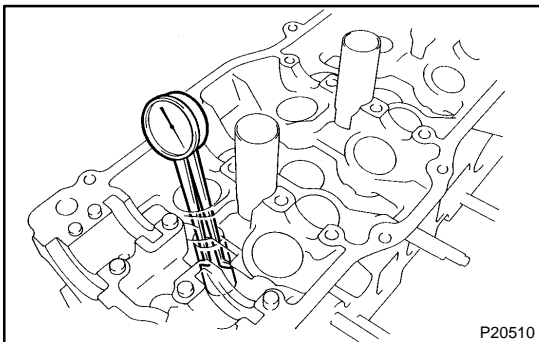

(d) Using a caliper gauge, measure the bushing bore diameter of the cylinder head.

(e) Select a new guide bushing (STD or O/S 0.05).

Both intake and exhaust

Bushing bore diameter mm (in.)	Bushing size
10.985 - 11.027 (0.4350 - 0.4341)	Use STD
11.050 - 11.077 (0.4350 - 0.4361)	Use O/S 0.05

If the bushing bore diameter of the cylinder head is greater than 11.027 mm (0.4341 in.), machine the bushing bore to these dimension:

11.050 – 11.077 mm (0.4350 – 0.4361 in.)

If the bushing bore diameter of the cylinder head is greater than 11.077 mm (0.4361 in.), replace the cylinder head.

(f) Gradually heat the cylinder head to 80 – 100°C (176 – 212°F).

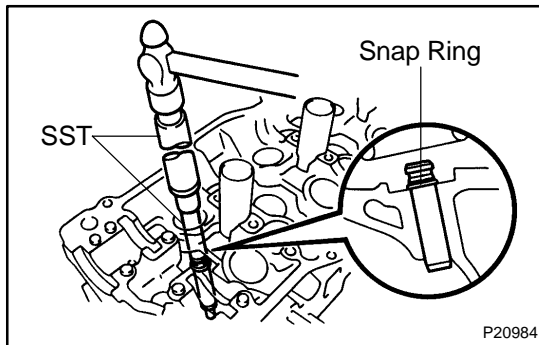

(g) Using SST and a hammer, tap in a new guide bushing until the snap ring makes contact with the cylinder head.
SST 09201-10000 (09201-01060), 09950-70010 (09951-07150)

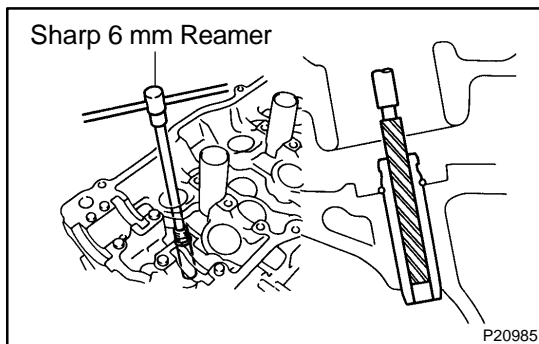

(h) Using a sharp 6 mm reamer, ream the guide bushing to obtain the standard specified clearance (See page [EM-38](#)) between the guide bushing and valve stem.

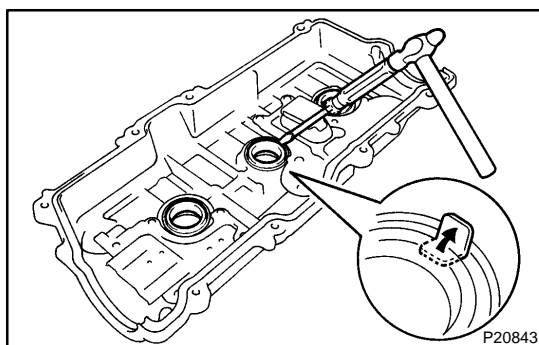

2. REPLACE SPARK PLUG TUBE GASKETS

- (a) Bend up the tab on the ventilation baffle plate which prevents the gasket from the slipping out.
(b) Using a screwdriver and hammer, tap out the gasket.

NOTICE:

Do not scratch or damage the joint of the cylinder head cover.

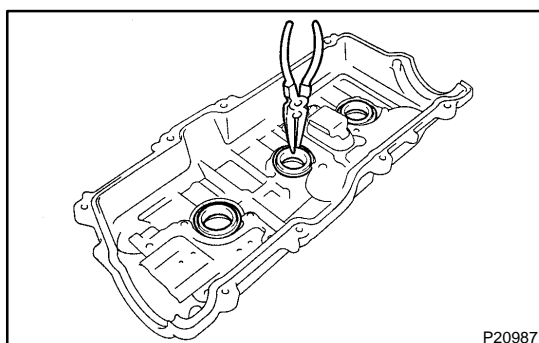

(c) Using needle-nose pliers, pry out the gasket.

ENGINE MECHANICAL (5VZ-FE) - CYLINDER HEAD

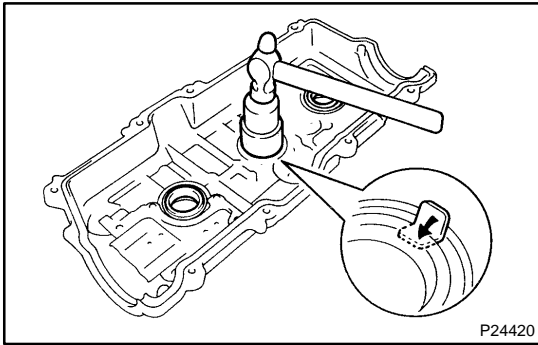

- (d) Using a 32 mm socket wrench and hammer, tap in a new gasket until its surface is flush with the upper edge of the cylinder head cover.
- (e) Apply a light coat of MP grease to the gasket lip.
- (f) Return the ventilation plate tab to its original position.